

The Promise and Fulfillment of the Holy Spirit. John 14:21–26

John 14:21–26 (NKJV)

²¹ He who has My commandments and keeps them, it is he who loves Me. And he who loves Me will be loved by My Father, and I will love him and manifest Myself to him.”

²² Judas (not Iscariot) said to Him, “Lord, how is it that You will manifest Yourself to us, and not to the world?”

²³ Jesus answered and said to him, “If anyone loves Me, he will keep My word; and My Father will love him, and We will come to him and make Our home with him. ²⁴ He who does not love Me does not keep My words; and the word which you hear is not Mine but the Father’s who sent Me.

²⁵ “These things I have spoken to you while being present with you. ²⁶ But the Helper, the Holy Spirit, whom the Father will send in My name, He will teach you all things, and bring to your remembrance all things that I said to you.

Introduction

In the last hundred years there have been amazing advancements throughout the world. Studies in technology and mechanics have given to us automobiles that drive themselves airplanes with autopilot advancements in the medical field, computers, laptops, iPads, iPhones.

Discoveries and inventions have surpassed any of our expectations

We have seen advancements in the medical community where there have been discoveries that have wiped out disease that used to destroy entire communities.

The studies and discovery of DNA alone have put us on the very edge of having some of the most amazing advancements in recent years.

Nothing can come close to what we have done in these last few years.

For instance

Buckminster Fuller created the “Knowledge Doubling Curve”; he noticed that until 1900 human knowledge doubled approximately every century. By the end of World War II knowledge was doubling every 25 years. Today things are not as simple as different types of knowledge have different rates of growth. For example, nanotechnology knowledge is doubling every two years and clinical knowledge every 18 months. But

on average human knowledge is doubling every 13 months. According to IBM, the build out of the “internet of things” will lead to the doubling of knowledge every 12 hours.

Human Brain Indexing Will Consume Several Billion Petabytes

In a recent lecture at Harvard University neuroscientist Jeff Lichtman, who is attempting to map the human brain, has calculated that several billion petabytes of data storage would be needed to index the entire human brain. (A megabyte is 1 million bytes, A

Gigabyte is 1 Thousand Megabytes, A Terabyte is 1000 Gigabytes and a Petabyte is 1000 Terabytes or 1 Thousand million, million, million bytes)

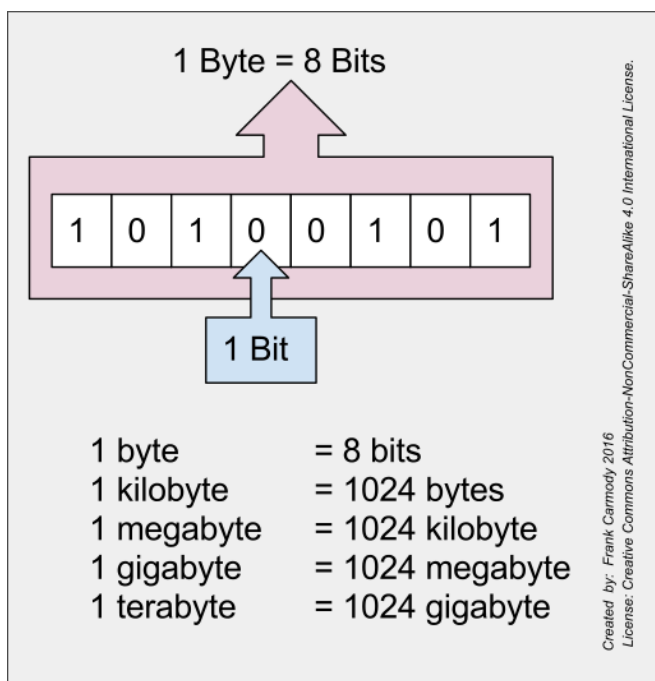

The (entire) Internet is currently estimated to be 5 million terabytes (TB) of which Google has indexed roughly 200 TB or just .

004% of its total size. The numbers involved are astounding especially when considering the size of the human brain and the number of neurons in it.

Linear to Exponential Growth of Human Knowledge

A transition from the linear growth of human knowledge to the exponential growth of human knowledge has taken place.. According to researchers dealing with this information will necessitate the development of vastly more complex software, shareability, and artificial intelligence.

As much as I appreciate the advancements that we have made that I have definitely made modern conveniences the lifestyle. And I am very thankful that Man has in mind that he can use that God is given him to discover these things and make these wonderful inventions.

Yet when it comes to spiritual things man seems to also think that he can advance himself in that area without any help from God.

Ever since the creation of man he has believed that he can figure out. As far back as Adam and Eve Cain and Able, The tower of Babel etc. But can he understand his own spiritual condition and solve it without any revelation from God? We see the

departure of Man from God recorded for us in the book of Romans chapter 1. He has all the evidence that there is a God yet refuses to believe in that God. And as a result he moves further and further away from the truth. And according to this chapter it says that he professes to be wise but he is a fool. Also says in Psalms 14 verse one that the **fool** has said in his heart there is no God.

נָבֵל adjective foolish, **senseless**, especially of the man who has no perception of ethical and religious claims

From **nabel**; stupid; wicked (especially impious)

Original Word: μωραίνω

Part of Speech: Verb

Transliteration: mōrainómōraínō (from 3474 /mōrós) – dull, sluggish ("without an edge"); (figuratively) acting "stupid or silly," "insipid, flat." . . . "to play the fool" (WS, 30). See 3474 (mōros).

1 Corinthians 2:14 (NKJV)

¹⁴ But the natural man does not receive the things of the Spirit of God, for they are foolishness to him; nor can he know *them*, because they are spiritually discerned.

Man left to himself cannot find God and cannot understand his spiritual condition. He is a blind dead man in a pitch black world with no life and no guidance.

Reminds me of Jeremiah 17

Jeremiah 17:5–10 (NKJV)

⁵ Thus says the Lord:

“Cursed *is* the man who trusts in man
And makes flesh his strength,
Whose heart departs from the Lord.

⁶ For he shall be like a shrub in the desert,
And shall not see when good comes,
But shall inhabit the parched places in the
wilderness,
In a salt land which is not inhabited.

⁷ “Blessed *is* the man who trusts in the Lord,
And whose hope is the Lord.

⁸ For he shall be like a tree planted by the waters,
Which spreads out its roots by the river,
And will not fear when heat comes;
But its leaf will be green,
And will not be anxious in the year of drought,
Nor will cease from yielding fruit.

⁹ “The heart *is* deceitful above all *things*,
And desperately wicked;

Who can know it?

¹⁰ I, the Lord, search the heart,
 / test the mind,
 Even to give every man according to his ways,
 According to the fruit of his doings.

The Church has had a hard time in recent years learning this

5 “Cursed *is* the man who trusts in man
 And makes flesh his strength,

9 “The heart *is* deceitful above all *things*,
 And desperately wicked;
 Who can know it?

The church seems to fashion itself to be an institution for the help of man with the tools of man, when quite the opposite if true. The church is body of Christ created for the Glory of God produced and matured through the His Spirit and His Word.

The modern evangelical church from the time it is planted, and organized, from its evangelism and means of worship, from the appointment of leadership and the discipleship of the saints has

become frighteningly man centered and man powered.

We have programs and Ph.Ds

We have psychotherapy and social clubs

We have psychology and self help groups.

We have more Freud than Faith

More Darwin than Deity.

Pastors are more and more looked at as CEOs of corporations than Shepherds of the flock and like the puritans referred to as Soul Doctors.

David Wells writes in his book,

“No place for Truth”

Regarding ‘Leadership’ magazine

“Of all the essays that appear between 1980 and 1988 less than one percent made even a remote reference to Scripture or any theological idea despite the fact many of the topics are treated in the Bible. As the journal turns away from the Bible to what it believe to be more fruit means of knowledge, it is redefining christian ministry and the pastor who accepts its point of view. In the study the evangelical pastor is the CEO, in the pulpit the pastor is a psychologist whose task it is to engineer good relations and warm feelings”

“A new species is now adrift in the world and is now washing up along the shores of evangelical life.

It is a species eager to exchange enduring qualities for a spat of exciting new experiences that thinks in terms of images rather than truths, that has no place from which to view the world and shifts from people to people in an attempt to catch the passing sights, a voyager rather than a thinker guided by a compass of circumstances rather than belief....

Simply put the psychologizing of the faith is destroying the christian mind. It is destroying Christians habits of thought because it is destroying the capacity to think about life in a Christian fashion. It is as if the top soil were being washed away leaving the land barren and incapable of being cultivated. It can no longer sustain the bountiful harvest of being able to discern between good and evil, to think about life in terms of God and His purposes... All of this is lost. And when people are no longer compelled by Gods Truth, they can be compelled by anything. The more so if it has the sheen of excitement or the lure of the novel.. the heretics of old, one would suspect, would envy if they know of the easy pickings that can now be had in the church”

You are told as a pastor in most seminaries today that if you have someone come to office who needs counseling and they don't understand the Trinity,

they you can help them. BUT if they say that they are a member of the Trinity then you need to refer them, because that is beyond you and you need to leave that to the professionals.

Just recently I witnessed that very thing.

The ERLC the SBC entity, hosted an event called “Caring Well”

The intention and reason was good. Its was organized and promoted for the purpose of helping churches deal with the rising problem of sexual abuse within churches.

Two things really stood out to me.

1st It was a platform to promote women in pastoral leadership, because women are better suited for dealing with this problem.

2. It made it very clear that the pastors are not capable of dealing with this complex problem and that these situations should be referred to the professionals.

In other words, Gods Word and His Spirit are not sufficient to deal with and help those who have experienced some of the most traumatic situations in life.

We need the ideas developed by men who don’t believe in God, His Word or His Spirit.

We will go out of our way to make things very complex when they just don't have to be. For thousands of years men and women lived without the help of Sigmund Freud and Charles Darwin. Yet today we think that we just can't let the Spirit of God do His work through the Word of God... that just seems to simple.....

It reminds me of what I

heard that when NASA first started sending up astronauts, they discovered that the ball point pen would not work in zero gravity. So to combat the problem, they spent a decade and 12 billion dollars to develop a pen that writes in zero gravity, upside down, underwater, and on glass or any other surface and from way below freezing to 300 degrees centigrade

The Russians just use the pencil

Let just get back to the pencil. The Written Word of God used by Spirit of God to totally transform man or woman of God.

Lesson

1. The Promise of Residence

2. The Promise of Revelation

²¹ He who has My commandments and keeps them, it is he who loves Me. And he who loves Me will be loved by My Father, and I will love him and manifest Myself to him.”

²² Judas (not Iscariot) said to Him, “Lord, how is it that You will manifest Yourself to us, and not to the world?”

²³ Jesus answered and said to him, “If anyone loves Me, he will keep My word; and My Father will love him, and We will come to him and make Our home with him.”

1. The Declaration

2. The Completion

v21

and I will love him and manifest Myself to him.”

22 Judas (not Iscariot) said to Him, “Lord, how is it that You will manifest Yourself to us, and not to the world?”

v23

We will come to him and make Our home with him.

manifest- FAI

emphanizó: to exhibit, appear (in person), to declare

Original Word: ἐμφανίζω

Part of Speech: Verb

Transliteration: emphanizó

Phonetic Spelling: (em-fan-id'-zo)

Definition: to exhibit, appear (in person), to declare

Usage: I make visible (manifest); hence: I report (inform) against; pass: I appear before.

ἐμφανίζω (see ἐν, III. 3); future ἐμφανίσω (Buttmann, 37 (32)); 1 aorist ἐνεφανισα; 1 aorist passive ἐνεφανίσθην; from Xenophon, and Plato down; (ἐμφανής);

1. to manifest, exhibit to view: ἐαυτόν τίνι, properly, to present oneself to the sight of another, manifest oneself to ([Exodus 33:13](#)), [John 14:22](#); metaphorically of Christ giving evidence by the action of the Holy Spirit on the souls of the disciples that he is alive in heaven, [John 14:21](#). Passive to Show oneself, come to view, appear, be manifest: τίνι (of spectres, Wis. 17:4; αὐτοῖς Θεοῦς

ἐμφανίζεσθαι λέγοντες, Diag. Laërtius prooem. 7; so of God, Josephus, Antiquities 1, 13, 1), [Matthew 27:53](#); τῷ προσώπῳ τοῦ Θεοῦ, of Christ appearing before God in heaven, [Hebrews 9:24](#); (of God imparting to souls the knowledge of himself, Wis. 1:2; Theophilus of Antioch ad Autol. 1, 2, 4).

2. to indicate, disclose, declare, make known:

followed by ὅτι, [Hebrews 11:14](#); with the dative of person [Acts 23:15](#); τί πρός τινα, [Acts 23:22](#); τί κατά τίνος, to report or declare a thing against a person, to inform against one, [Acts 24:1](#); [Acts 25:2](#); περί τίνος, about one, [Acts 25:15](#). (Synonym: see δηλώω.)

Although this verb is used of a physical manifestation a number of times,

Like

Matthew 27:52–53 (NKJV)

⁵² and the graves were opened; and many bodies of the saints who had fallen asleep were raised; ⁵³ and coming out of the graves after His resurrection, they went into the holy city and **appeared** to many.

Hebrews 9:24 (NKJV)

²⁴ For Christ has not entered the holy places made with hands, *which are* copies of the true, but into heaven itself, now to **appear** in the presence of God for us;

I believe that Jesus has more in mind here than just that.

Reasons

1. The verb has been used for more than just physical appearance.

Acts 23:15 (NKJV)

¹⁵ Now you, therefore, together with the council, **suggest** to the commander that he be brought down to you tomorrow, as though you were going to make further inquiries concerning him; but we are ready to kill him before he comes near.”

Acts 23:22 (NKJV)

²² So the commander let the young man depart, and commanded *him*, “Tell no one that you have **revealed** these things to me.”

Acts 24:1 (NKJV)

1. Now after five days Ananias the high priest came down with the elders and a certain orator *named* Tertullus. These **gave evidence** to the governor against Paul.

Acts 25:2 (NKJV)

² Then the high priest and the chief men of the Jews **informed** him against Paul; and they petitioned him,

So we see this can also mean.

to make clear, through the revelation of information

2. The Answer that Jesus Gives to the disciple indicates more than a physical appearance. This is the promise of the Presence and Indwelling of the Holy Spirit.

22 Judas (not Iscariot) said to Him, “Lord, how is it that You will manifest Yourself to us, and not to the world?”

v23

We will come to him and make Our home with him.

Here Jesus says that not only will He but also the Father and as we know from other verses that the

Holy Spirit will come and make their Home in with us.

John 14:16–18 (NKJV)

¹⁶ And I will pray the Father, and He will give you another Helper, that He may abide with you forever —¹⁷ the Spirit of truth, whom the world cannot receive, because it neither sees Him nor knows Him; but you know Him, for He dwells with you and will be in you. ¹⁸ I will not leave you orphans; I will come to you.

John 16:7 (NKJV)

⁷ Nevertheless I tell you the truth. It is to your advantage that I go away; for if I do not go away, the Helper will not come to you; but if I depart, I will send Him to you.

3. Verse 26 indicates how Jesus will manifest Himself to them through illumination and Revelation.

John 14:26 (NKJV)

²⁶ But the Helper, the Holy Spirit, whom the Father will send in My name, He will teach you all things,

and bring to your remembrance all things that I said to you.

So this promise of Manifest Christ to the Disciple is tied to the the coming of the Holy Spirit to permanently indwell the body of Christ.

23 Jesus answered and said to him, “If anyone loves Me, he will keep My word; and My Father will love him, and We will come to him and make Our home with him.

John 14:16 (NKJV)

¹⁶ And I will pray the Father, and He will give you another Helper, that He may abide with you forever

—

John 15:26 (NKJV)

²⁶ “But when the Helper comes, whom I shall send to you from the Father, the Spirit of truth who proceeds from the Father, He will testify of Me.

1. The Declaration

2. The Completion

The Promises was fulfilled

Luke 24:49 (NKJV)

⁴⁹ “Behold, I send the Promise of My Father upon you; but tarry in the city of Jerusalem until you are endued with power from on high.”

The Promise of the Holy Spirit

Acts 1:4–8 (NKJV)

⁴ And being assembled together with *them*, He commanded them not to depart from Jerusalem, but to wait for the Promise of the Father, “*which,*” *He said,* “*you have heard from Me;* ⁵ *for John truly baptized with water, but you shall be baptized with the Holy Spirit not many days from now.*” ⁶ Therefore, when they had come together, they asked Him, saying, “Lord, will You at this time restore the kingdom to Israel?” ⁷ And He said to them, “*It is not for you to know times or seasons which the Father has put in His own authority.*” ⁸ *But you shall receive power when the Holy Spirit has come upon you; and you shall be witnesses to Me in Jerusalem, and in all Judea and Samaria, and to the end of the earth.”*

The Coming of the Holy Spirit

Acts 2:1–4 (NKJV)

2 When the Day of Pentecost had fully come, they were all with one accord in one place. ² And suddenly there came a sound from heaven, as of a rushing mighty wind, and it filled the whole house where they were sitting. ³ Then there appeared to them divided tongues, as of fire, and *one* sat upon each of them. ⁴ And they were all filled with the Holy Spirit and began to speak with other tongues, as the Spirit gave them utterance.

The Crowd's Response

Acts 2:5–6 (NKJV)

⁵ And there were dwelling in Jerusalem Jews, devout men, from every nation under heaven. ⁶ And when this sound occurred, the multitude came together, and were confused, because everyone heard them speak in his own language.

Acts 2:8–11 (NKJV)

⁸ And how *is it that* we hear, each in our own language in which we were born? ⁹ Parthians and

Medes and Elamites, those dwelling in Mesopotamia, Judea and Cappadocia, Pontus and Asia, ¹⁰ Phrygia and Pamphylia, Egypt and the parts of Libya adjoining Cyrene, visitors from Rome, both Jews and proselytes, ¹¹ Cretans and Arabs—we hear them speaking in our own tongues the wonderful works of God.”

Acts 2:14–17 (NKJV)

¹⁴ But Peter, standing up with the eleven, raised his voice and said to them, “Men of Judea and all who dwell in Jerusalem, let this be known to you, and heed my words. ¹⁵ For these are not drunk, as you suppose, since it is *only* the third hour of the day. ¹⁶ But this is what was spoken by the prophet Joel:

¹⁷ *‘And it shall come to pass in the last days, says God,
That I will pour out of My Spirit on all flesh;
Your sons and your daughters shall prophesy,
Your young men shall see visions,
Your old men shall dream dreams.*

Acts 8:12–17 (NKJV)

¹² But when they believed Philip as he preached the things concerning the kingdom of God and the name

of Jesus Christ, both men and women were baptized. ¹³ Then Simon himself also believed; and when he was baptized he continued with Philip, and was amazed, seeing the miracles and signs which were done.

¹⁴ Now when the apostles who were at Jerusalem heard that Samaria had received the word of God, they sent Peter and John to them, ¹⁵ who, when they had come down, prayed for them that they might receive the Holy Spirit. ¹⁶ For as yet He had fallen upon none of them. They had only been baptized in the name of the Lord Jesus. ¹⁷ Then they laid hands on them, and they received the Holy Spirit.

Acts 10:42–46 (NKJV)

⁴² And He commanded us to preach to the people, and to testify that it is He who was ordained by God *to be* Judge of the living and the dead. ⁴³ To Him all the prophets witness that, through His name, whoever believes in Him will receive remission of sins.”

⁴⁴ While Peter was still speaking these words, the Holy Spirit fell upon all those who heard the word. ⁴⁵ And those of the circumcision who believed were astonished, as many as came with Peter, because

the gift of the Holy Spirit had been poured out on the Gentiles also. ⁴⁶ For they heard them speak with tongues and magnify God.

Acts 19:1–6 (NKJV)

19 And it happened, while Apollos was at Corinth, that Paul, having passed through the upper regions, came to Ephesus. And finding some disciples ² he said to them, “Did you receive the Holy Spirit when you believed?”

So they said to him, “We have not so much as heard whether there is a Holy Spirit.”

³ And he said to them, “Into what then were you baptized?”

So they said, “Into John’s baptism.”

⁴ Then Paul said, “John indeed baptized with a baptism of repentance, saying to the people that they should believe on Him who would come after him, that is, on Christ Jesus.”

⁵ When they heard *this*, they were baptized in the name of the Lord Jesus. ⁶ And when Paul had laid hands on them, the Holy Spirit came upon them, and they spoke with tongues and prophesied.

Acts 10:45–46 (NKJV)

⁴⁵ And those of the circumcision who believed were astonished, as many as came with Peter, because the gift of the Holy Spirit had been poured out on the Gentiles also. ⁴⁶ For they heard them speak with tongues and magnify God.

Then Peter answered,

1 Corinthians 6:19 (NKJV)

¹⁹ Or do you not know that your body is the temple of the Holy Spirit *who is* in you, whom you have from God, and you are not your own?

1 Corinthians 3:16 (NKJV)

¹⁶ Do you not know that you are the temple of God and *that* the Spirit of God dwells in you?

2 Corinthians 6:16 (NKJV)

¹⁶ And what agreement has the temple of God with idols? For you are the temple of the living God. As God has said:

*“I will dwell in them
And walk among them.
I will be their God,
And they shall be My people.”*

Ephesians 2:22 (NKJV)

²² in whom you also are being built together for a dwelling place of God in the Spirit.

Hebrews 3:6 (NKJV)

⁶ but Christ as a Son over His own house, whose house we are if we hold fast the confidence and the rejoicing of the hope firm to the end.

Ezekiel 36:27 (NKJV)

²⁷ I will put My Spirit within you and cause you to walk in My statutes, and you will keep My judgments and do *them*.

Romans 8:11 (NKJV)

¹¹ But if the Spirit of Him who raised Jesus from the dead dwells in you, He who raised Christ from the dead will also give life to your mortal bodies through His Spirit who dwells in you.

2 Timothy 1:14 (NKJV)

¹⁴ That good thing which was committed to you, keep by the Holy Spirit who dwells in us.

1 John 4:12 (NKJV)

¹² No one has seen God at any time. If we love one another, God abides in us, and His love has been perfected in us.

1 John 4:15–17 (NKJV)

¹⁵ Whoever confesses that Jesus is the Son of God, God abides in him, and he in God. ¹⁶ And we have known and believed the love that God has for us. God is love, and he who abides in love abides in God, and God in him

2. The Promise of Revelation

John 14:26 (NKJV)

²⁶ **But the Helper, the Holy Spirit, whom the Father will send in My name, He will teach you all things, and bring to your remembrance all things that I said to you.**

John 16:13–15 (NKJV)

¹³ **However, when He, the Spirit of truth, has come, He will guide you into all truth; for He will not speak on His own *authority*, but whatever He hears He will speak; and He will tell you things to come.** ¹⁴ **He will glorify Me, for He will take of what is Mine and declare *it* to you.** ¹⁵ **All things that the Father has are**

Mine. Therefore I said that He will take of Mine and declare *it* to you.

1. Illumination
2. Inspiration